



The Safest Bumper Pull Trailers for Easier Loading

The quickest, easiest, and SAFEST way to haul your horses...
... without upgrading your truck or spending a fortune!



A Trailer You Can Proudly Show Off!

Double D Trailers has a variety of bumper pull trailers for 1-4 horses — built to match your exact needs and preferences.

Need a different size or customized horse features? Just ask. Send us a text now at 910-444-2880.

If you can dream it, we can build it.

Best of all, our trailers are packed with unique safety features you won't find anywhere else:

- Reverse load options for more comfortable travel,
- SafeTack design for less stressful loading and unloading, (images to the left)
- “Stay cool construction” which outperforms a standard aluminum model,
- And expert service for every stage of the buying process – including design assistance, \$395 flat-rate delivery, towing guidance, and a nationwide warranty service program and guarantee.



Explore this brochure and begin to customize your very own dream trailer!

Since 1997, custom horse trailers from Double D Trailers have provided the most innovative safety features in the industry.

Double D Trailers is different from other brands because of our emphasis on safety...

Our one-of-a-kind safety features work in harmony to protect both you and your horse.



SafeTack® Design (patented)	SafeKick® Walls	Z-Frame® Structure
Rumber Flooring	SafeBump® Ceilings	Reverse Load Layout
Tubular Dividers	Full Insulation	Quiet Interior



Happy Customers Share Their Experience Buying Online from Double D Trailers

Google Reviewed 4.5+

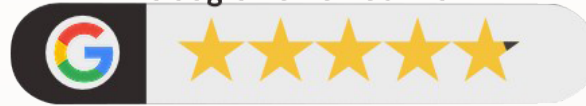

Nancy E. of Cedar City, Utah purchased a warmblood sized 2 horse bumper pull trailer with a dressing room. She shared...



"Great, great service!! Although it was scary ordering on line (never having seen the trailer) but it is everything DDT said and more!! Could not be happier with an "unseen" product."

Safety was a main priority in ordering a trailer for Christy I. of Atlanta, GA. She purchased a SafeTack 2 horse bumper pull trailer with a dressing room...



"I LOVED all of the safety features and options that Double D has included. I wanted to know that my horse was as safe as possible on the road and I feel that Double D Trailers has created a very safe product that provides as much protection as I can get in a Bumper Pull."

Curt and his wife in Abilene, Kansas looked at a wide variety of brands before settling on Double D Trailers. When asked about their specific needs, Curt replied...



"Safety, Safety, Safety....The fact that it was a really well built and great looking trailer was a plus too. The excellent customer service right from the beginning was incredible. We were kept updated constantly, and our needs were the priority not Double D's needs. We found that refreshing."

★ [Read more Google reviews.](#) ★

Top Safety Features on Our Bumper Pull Trailers

SafeTack® Design (patented)

Eliminates the dangerous narrow doorway found on conventional slant load trailers. Instead, a lockable tack area swings out like a second door, allowing an extra wide loading area.

SafeKick® Walls and SafeBump® Ceiling

Flexible and durable composite materials on the walls and ceiling protect your horse from injury.

Patented Z-Frame®

Lightweight Construction

Superior strength over aluminum protects your horses in case of an accident. Our 16-gauge Galvalite skin is 5 times stronger than 0.040 aluminum for an overall lightweight trailer.

Rubber Flooring

Aluminum floors corrode and weaken with time. Rubber provides lasting durability and easy cleaning. Plus, it reduces noise and vibration to lower stress levels and minimize leg fatigue.



Click to design
your trailer with
our **FREE** tool!



Top Safety Features on Our Bumper Pull Trailers

'Green' Design

We've nixed the use of many harmful chemicals in our manufacturing process.

Patented Reverse Load Trailer Models

Studies have shown that horses are less stressed and fatigued after riding in a rear-facing trailer.

Tubular Dividers

Increase air flow and visibility with see-through tubular head dividers.

Quiet Interior

Rivet-free design, secure divider fasteners, and floor materials create a quieter interior so your horse can relax.

100% Fully Insulated - "Stay cool!"

Enjoy comfortable temperatures year-round with full insulation from front to rear. All materials - even the paint colors - are chosen with temperature and safety in mind.



Click to design
your trailer with
our **FREE** tool!

How to Safely Tow a Bumper Pull Trailer

Horseowners love bumper pull trailers because they can 'hitch-and-go' without a lot of hassle. Still, it's important to have the right tow vehicle for safety.

Everyday, we hear stories of horse owners who put themselves in unsafe situations. That's why our team loves talking to horse owners to answer questions about safe towing. **Just ask us!**

To start, there are really only two numbers you need to pay attention to:

#1: Tow rating – This is what the manufacturer says a vehicle will pull.

#2: Payload – This is what the manufacturer says a vehicle will "carry." Payload is often not obvious but you can easily calculate it by using the following: $GVWR - \text{Curb weight} = \text{Payload}$

Once you have these two numbers, all you'll need to learn is the trailer's weight and tongue weight which the trailer builder can provide. Make sure the hitch you are using is properly rated to carry that tongue weight. Use our **tongue weight calculator** if you're not sure.

To be on the safe side, we always suggest you talk with our Double D Trailer towing experts to make sure your new trailer can be towed safely.



Click to design your trailer with our **FREE** tool!

Can't Decide Between a Slant Load & Straight Load Horse Trailer?

Each option has its pros and cons. Think about how many horses you want to haul and whether you'll need extra space for tack storage and a dressing room.

Straight load trailers from most brands often cost less and work well for larger horses. However, many animals don't like to "back out" of a straight load trailer. Plus, dropping the butt bar into place behind an unruly horse can be dangerous for the handler.

Slant load trailers from Double D Trailers can be specially built for breeds of all sizes, including large breeds and warmbloods. Our SafeTack design eliminates the narrow and scary loading door found on most slant load models.

Instead, the rear tack storage area swings out like a second door to allow a wide loading and unloading space. Add a side horse ramp and rear facing design for a true walk-on-walk-off experience.

Research suggests horses haul with less stress and fatigue in the reverse configuration.

Lastly, slant load horse trailers make better use of space with a shorter wheel base. It is often easier to include features like dressing rooms on these models while preserving driving maneuverability.

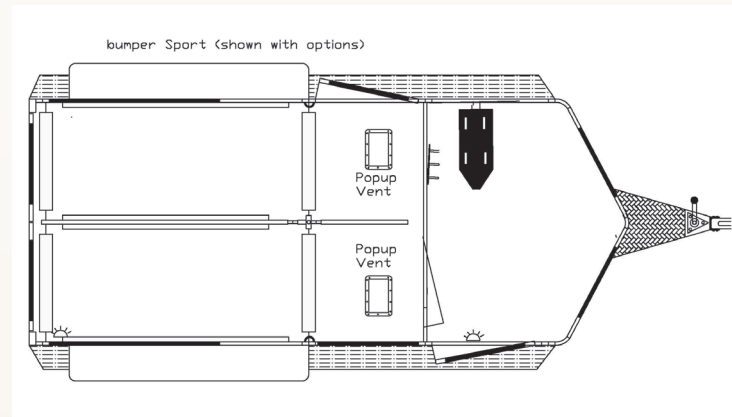

Traditional Straight Load

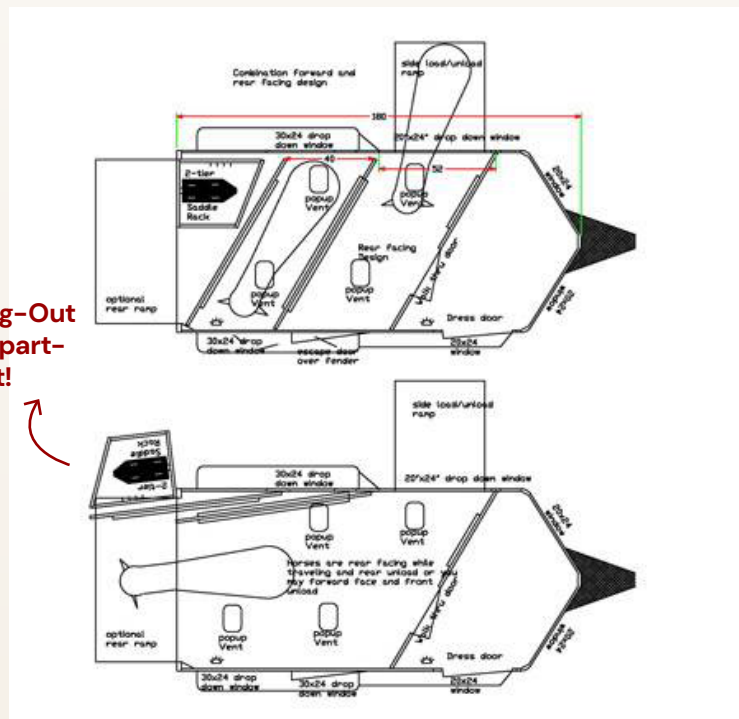

Swing-Out
Compartment!

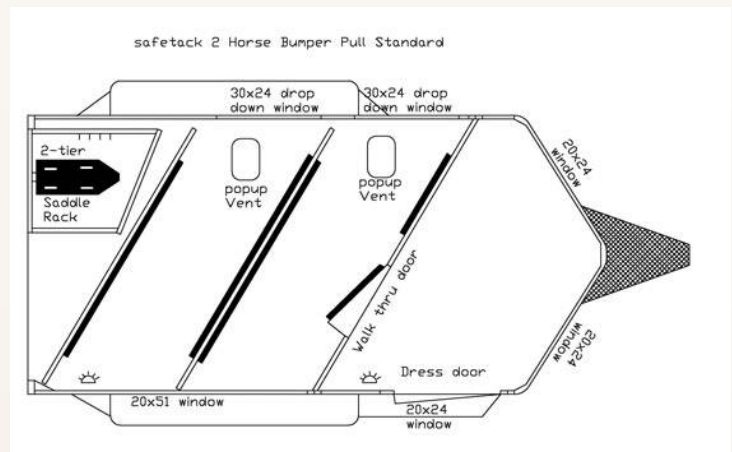

**(Above) Forward Facing SafeTack Slant Load
(Left) Reverse SafeTack Slant Load
with Side Ramp**

Click to design
your trailer with
our **FREE** tool!

Get Your Dream Dressing Room on a Bumper Pull Horse Trailer

Your bumper pull horse trailer can be designed with a spacious dressing room for storage, changing, or even sleep!

Your Double D Trailer can be designed with a large front dressing room. Store overnight supplies, show gear, food, and chairs. Customize the space with hooks for a hammock or include a cot or mattress for hassle-free camping.

Add a roll-out patio awning to transform your trailer into a mini shaded retreat for you and your horses.

Remember, your sweaty horse blankets and tack can be kept locked in the rear SafeTack storage area – leaving more room up front for your human comforts.

If you are looking for full living quarters complete with plumbing and a kitchenette, check out our **one horse living quarters bumper pull trailer** on page 15.

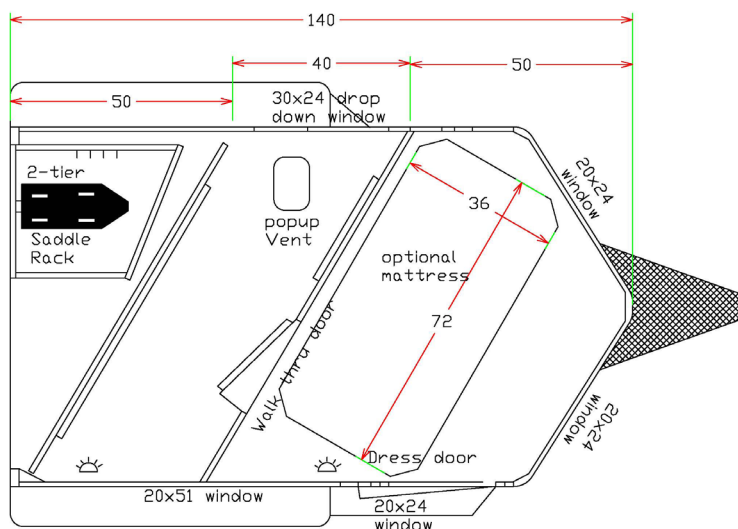

1 Horse Slant Load Dressing Room with Optional Mattress



Go Online to Start Designing Your Custom Horse Trailer Today

It's easy and even FUN! Here is the entire process in seven steps.

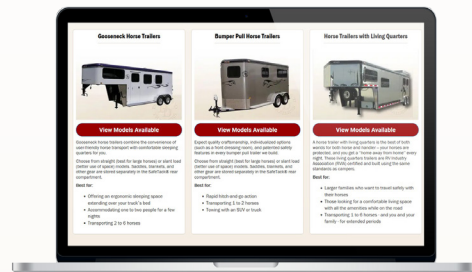

Step 1: Use our FREE Tool to Start Designing Your Trailer.

On our homepage, click the big red button that says "Start Designing Your Trailer" to start choosing features for your dream trailer. Or, click the gold medallion below!

Step 2: Submit an Online Build Request

Select one of the suggested models and click "Customize" to start checking off boxes for the features you'd love to have. Review your trailer and give us some information about yourself so we can get in touch. Click "Submit Build." No cost or obligation.

Step 3: Detailed Pricing Estimate

Once you submit your request, our team will review your selection and look for any feature conflicts. For example, it is not possible to select both a front escape door and a manger. Once reviewed, we will next send a detailed pricing estimate.



Click to design your trailer with our **FREE** tool!

Step 4: Design Discussion with Our Experts

You will then begin an ongoing conversation with our experts to refine the design and establish the final pricing. We can help you add in special requests or remove unneeded features to stay within a budget. Don't worry. Our design team makes this step fun!

Step 5: CAD Drawing

A highly detailed CAD drawing will act as the construction blueprint for our building team. Here's an example of what that looks like.

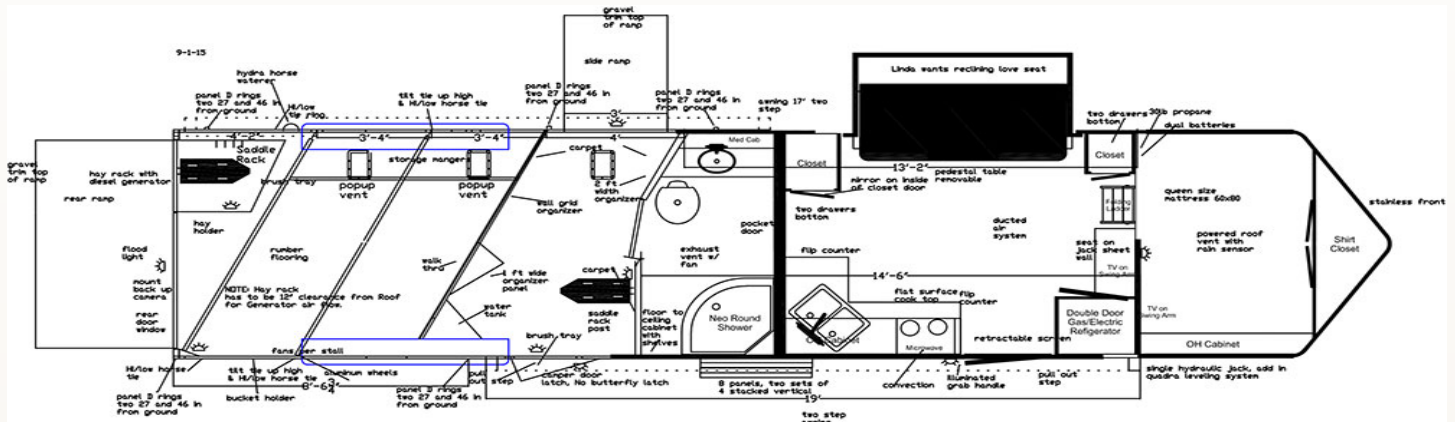

Step 6: Approval and Start of Construction

Once you are happy with the final design, pricing, and order details, the estimate is converted to an official order. We will begin construction on your new trailer!

Step 7: Final Touches

Any decorative features like outside graphic and color can be determined after the trailer construction has begun. From here, you can sit back and relax until your brand new trailer is delivered to your driveway.



Slant Load Bumper Pull Trailers: Features Overview

Click on any model to customize →	SafeTack Slant Load 2H	SafeTack Slant Load 3H	SafeTack Slant Load 1H	SafeTack 1H Bumper Pull w/ Living Quarters
Frame	Z-Frame Technology	Z-Frame Technology	Z-Frame Technology	Z-Frame Technology
Skin Interior and Exterior	16 Gauge Gavalite strong and safe horse area; aluminum exterior	16 Gauge Gavalite strong and safe horse area; aluminum exterior	16 Gauge Gavalite strong and safe horse area; aluminum exterior	16 Gauge Gavalite strong and safe horse area; aluminum exterior
Side Walls	Insulated horse area for max temp protection & quiet ride	Insulated horse area for max temp protection & quiet ride	Insulated horse area for max temp protection & quiet ride	Insulated horse area for max temp protection & quiet ride
Dividers	Z-Frame Technology with Safety Slam Technology	Z-Frame Technology with Safety Slam Technology	Z-Frame Technology with Safety Slam Technology	Z-Frame Technology
Roof	Fiber-composite 1-piece no-leak SafeBump roof	Fiber-composite 1-piece no-leak SafeBump roof	Fiber-composite 1-piece no-leak SafeBump roof	Fiber-composite 1-piece no-leak SafeBump roof
Options	Full Customization Options	Full Customization Options	Full Customization Options	Full Customization Options
Horses	2H	3-4H	1H	1H
SafeTack	Yes	Yes	Yes	Yes
Side Ramp	Side ramp and door are an option	Side ramp and door are an option	No side ramp and door available.	No side ramp and door available.
Trailer Width	80" width & 7'4" height standard	80" width & 7'4" height standard	80" width & 7'4" height standard	80" width & 7'4" height standard
Horse Orientation	Combination Forward or Reverse Facing Option	Combination Forward or Reverse Facing Option	Forward Facing Only.	Forward Facing Only.
Horse Sizes That Can Be Hauled	Standard up to 15.3H / 1,100 lbs. Options to fit 17+H Warmbloods comfortably	Standard up to 15.3H / 1,100 lbs. Options to fit 17+H Warmbloods comfortably	Standard up to 15.3H / 1,100 lbs. Options to fit 17+H Warmbloods comfortably	Standard up to 15.3H / 1,100 lbs. Options to fit 17+H Warmbloods comfortably
Flooring	Treated Pine or Rumber	Treated Pine or Rumber	Treated Pine or Rumber	Treated Pine or Rumber
Walls	SafeKick Wall System	SafeKick Wall System	SafeKick Wall System	SafeKick Wall System
Padding	Custom Hand Made 2"	Custom Hand Made 2"	Custom Hand Made 2"	Custom Hand Made 2"
Extra Rear Safety Divider	Yes	Yes	Yes	Yes, with safety slam technology.
Dressing Room	Yes	Yes	Yes	Full Living Quarters!

Safetack Slant Load 2 Horse Bumper Pull Horse Trailers

Customize This Model

- Z-Frame® technology to create a durable and strong chassis.
- Unique, safe and functional rear SafeTack® technology
- Z-Frame® tubular head dividers to create more air flow and less stress on your horses.
- A convenient walk thru door from the dress to the horse area.
- SafeBump Roof® and SafeKick® Wall Systems to keep your horses protected.
- Reverse Haul Horse Trailer Design available.

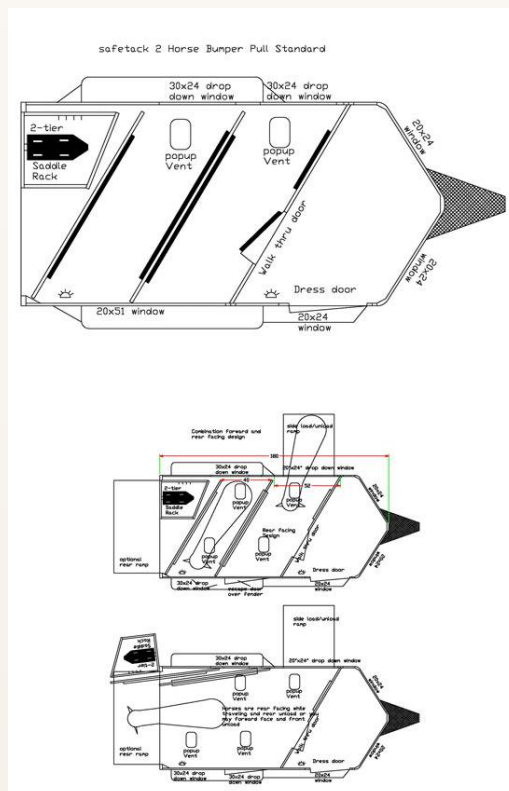

3 Horse Bumper Pull Slant Load Trailers

Customize This Model

- Z-Frame® technology to create a durable and strong chassis.
- Unique, safe and functional rear SafeTack® technology
- Z-Frame® tubular head dividers to create more air flow and less stress on your horses.
- A convenient walk thru door from the dress to the horse area.
- SafeBump Roof® and SafeKick® Wall Systems to keep your horses protected.
- Rear facing Horse Trailer Design available (Often referred to as riding backwards).

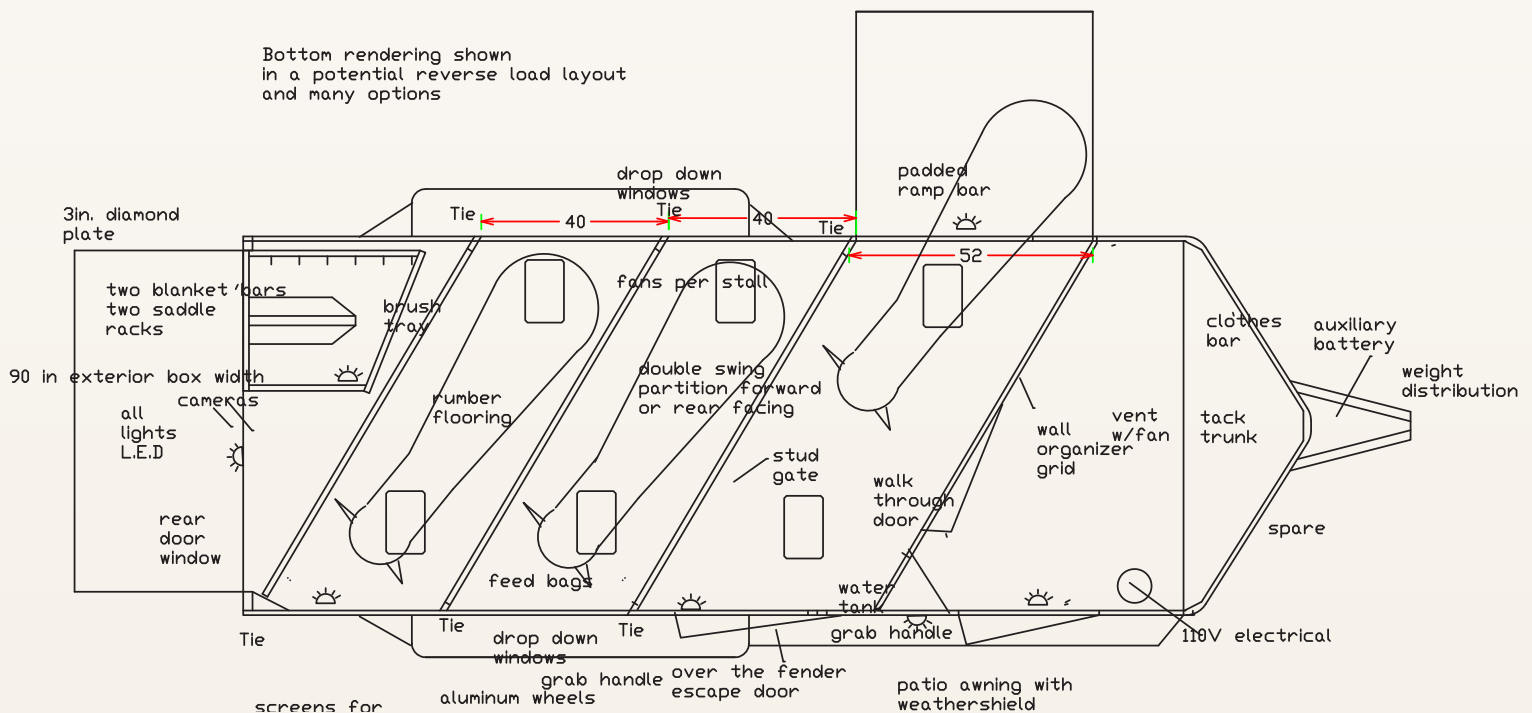

1 Horse Bumper Pull Slant Load Trailers

Customize This Model

- The Safest One Horse Trailer
- Innovative and light weight
- Walk on and walk off feature
- Anti-kick divider standard (prevents you from getting kicked!)
- Potty door included
- Available for any size horse

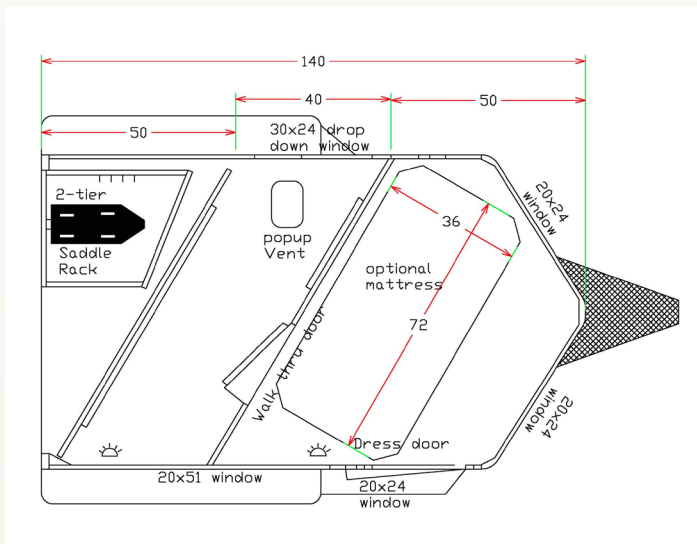

One Horse Bumper Pull with Living Quarters Trailer

Customize This Model

If you own just one horse and you want convenient living quarters without the hassle of a huge trailer, this model is perfect for you!

This is our popular one horse living quarters horse trailer that weighs only 5,100 lbs with a tongue weight of only 600 lbs. This means it's the perfect little trailer to transport your single prized horse. The living quarters area has a drop down dinette for eating which converts into a bed. A small kitchenette is available for meal prep along with a bathroom.

Please note, this is one of the ONLY safe bumper pull living quarters model on the market. Since it only carries a single horse, we can be sure of load distribution. Other bumper pull living quarter models on the market for 2+ horses often have unsafe axle placement. This results in excessive tongue weight on the tow vehicle, or in some cases, even negative tongue weight which can cause dangerous trailer sway.



- Z-Frame Technology
- Easy to tow with a half ton pick up truck or full size SUV. Tongue weight of only 600 lbs and trailer weight of 5,100 lbs.
- SafeKick® Wall System
- One Piece Fiber composite SafeBump Roof system. (It can't ever leak.)
- Standard size stall will support a horse up to a 15.2. Optional 16.2 Thoroughbred option or 17 hand warmblood.
- Customize features tailored to your specific hauling requirements and need.
- Ideal for one person and one horse

Straight Load Bumper Pull Trailers: Features Overview

Click on any model to customize ->	Townsmant 2 Horse	V-Sport 2 Horse	Bumper Sport 2 Horse
Basic Desc	Basic 2H straight load model, compact option with saddles stored under manger	Middle of the road 2H straight load, longer than Townsmant, no manger, saddles stored in the v-nose	Fully-stocked 2H straight load, longest model with separate tack room in the front.
Horses	2H	2H	2H
Windows	Yes	Yes	Yes
Frame	Z-Frame Technology	Z-Frame Technology	Z-Frame Technology
Dividers	Z-Frame Tubular Head Dividers with 2" handmade padding	Z-Frame Tubular Head Dividers with 2" handmade padding	Z-Frame Tubular Head Dividers with 2" handmade padding
Bars	Padded butt & breast bars	Padded butt & breast bars	Padded butt & breast bars
Doors	Front Walk Thru Door to Exterior	Front Walk Thru Door to Exterior	Front Walk Thru Door to Exterior
Manger	Manger for 1 stall	No	No
Tack Storage	Half height tack storage area	Optional saddle rack in V-nose	In dressing room
Dressing Room	No	No	Yes, Customizable
Side Unload Door & Ramp	Not available	Not available	Optional
Skin Interior & Exterior	16 Gauge Gavalite strong/safe horse area; aluminum exterior	16 Gauge Gavalite strong/safe horse area; aluminum exterior	116 Gauge Gavalite strong/safe horse area; aluminum exterior
Side Walls	Insulated horse area for max temp protection, safe, quiet ride	Insulated horse area for max temp protection, safe, quiet ride	Insulated horse area for max temp protection, safe, quiet ride
Roof	Fiber-composite one-piece no-leak SafeBump roof system	Fiber-composite one-piece no-leak SafeBump roof system	Fiber-composite one-piece no-leak SafeBump roof system
SafeTack	No	No	No
Trailer Width & Height	72" width & 7'6" height standard, can be enlarged for large breeds	72" width & 7'6" height standard, can be enlarged for large breeds	72" width & 7'6" height standard, can be enlarged for large breeds
Orientation	Forward Facing Only	Forward Facing Only	Forward Facing Only
Horse Sizes	Comes standard to fit horses up to 16.2H / 1,200lb, Option to fit larger 17+H horses	Comes standard to fit horses up to 16.2H / 1,200lb, Option to fit larger 17+H horses	Comes standard to fit horses up to 16.2H / 1,200lb, Option to fit larger 17+H horses
Flooring	Treated Pine or Rumber	Treated Pine or Rumber	Treated Pine or Rumber
Walls	SafeKick Wall System	SafeKick Wall System	SafeKick Wall System

Townsmant Bumper Pull Straight Load 2 Horse Trailer

Customize This
Model

- Basic 2H straight load model, compact option with saddles stored under manger
- Z-Frame® technology to create a durable and strong chassis.
- Z-Frame® tubular head dividers to create more air flow and less stress on your horses.
- A convenient walk thru door out the front of your trailer
- SafeBump Roof® and SafeKick® Wall Systems to keep your horses protected.

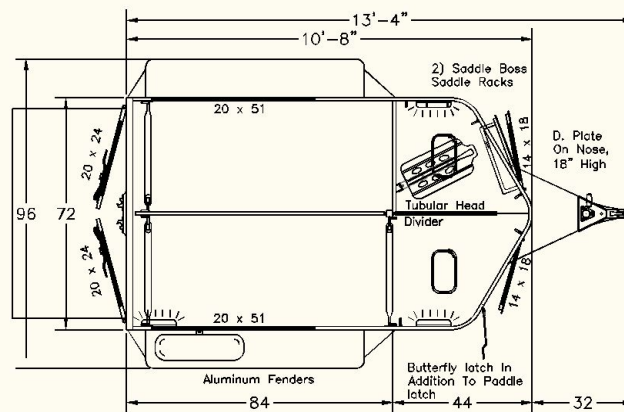

V-Sport Bumper Pull 2 Horse Straight Load Trailer

Customize This Model

- Middle of the road 2H straight load, longer than Townsmand with no manger, saddles stored in the v-nose
- Z-Frame Technology
- Z-Frame tubular head dividers standard (more air flow, less stress on your horses)
- V-Nose in the front walk in tack room
- SafeBump and SafeKick® Wall System

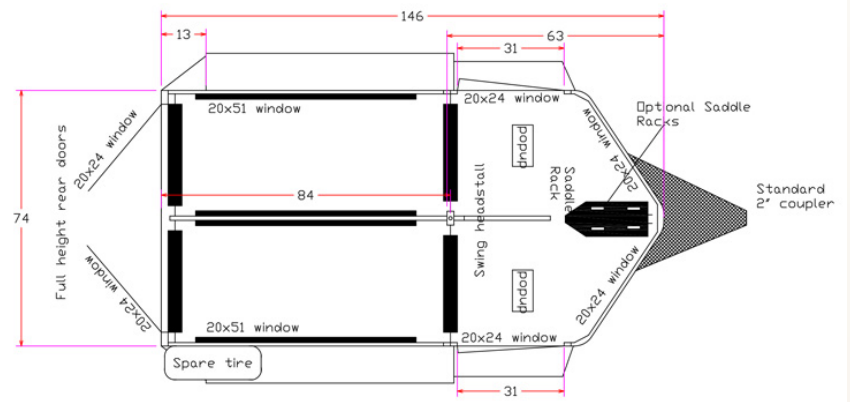

Bumper Sport 2 Horse Straight Load Bumper Pull Horse Trailer

Customize This
Model

- Fully-stocked 2H straight load, longest model with separate tack room in the front.
- Z-Frame® technology to create a durable and strong chassis.
- Z-Frame® See Through tubular head dividers to create more air flow and less stress on your horses.
- A convenient walk thru door from the dress to the horse area.
- SafeBump Roof® and SafeKick® Wall Systems to keep your horses protected.
- Customizable to fit up to an 18 hand horse.

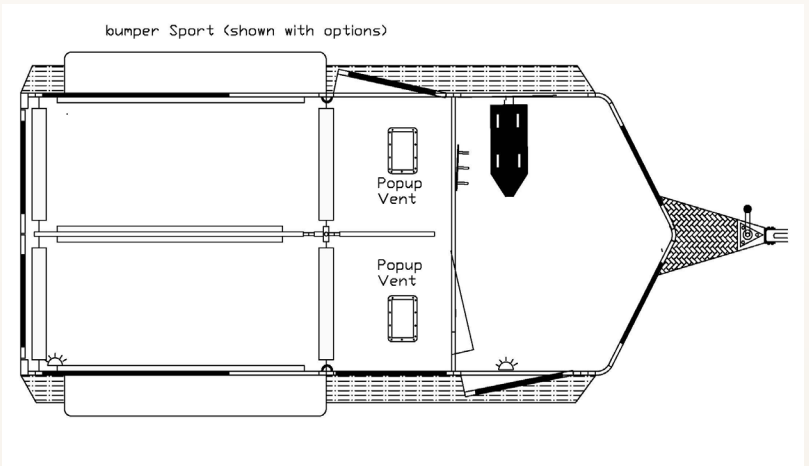

All Features Available on Bumper Pull Horse Trailers

- Z Frame Technology
- 2"x 8" Pressure Treated Pine Flooring on 16" Cross Members
- Rubber Flooring
- Walk Thru Door to Horse Area in slant wall (specify location and direction of swing)
- EZ Lube Durable Never Adjust Brakes
- Full Height Rear Doors with SafeTack Design
- 24" Diamond Plate Gravel Guard at Nose
- Running Board Step Down Dressing Room Side
- Carpet in Dressing Room Floor
- SafeTack® Slant Load Design, allows for entire back of trailer to be open for loading and unloading. Very safe
- Marker Lights on Fender
- Extra divider on rear stall to prevent horses from backing out when rear doors are opened
- Spare Tire inside dressing room
- Z-Frame Slant dividers with handmade padding and safety slam latches
- Horse Area Roof Vents, one per stall aluminum
- Custom handmade padding on dividers and slant wall
- 30" Dress Door Factory Built Door
- SafeKick® Wall System
- Heat reflective SafeBump® Roof System in new leak proof fiber composite material
- Insulated side walls in horse area for maximum temperature protection and safe, quiet ride
- Floor Mats in Horse Area
- Horse Area Roof Vents (One Per Horse)
- Rechargeable Emergency Breakaway System
- 7-Pin RV Style Plug
- Warranty on Structure, Bumper-to-Bumper, Non Double D Manufactured Parts

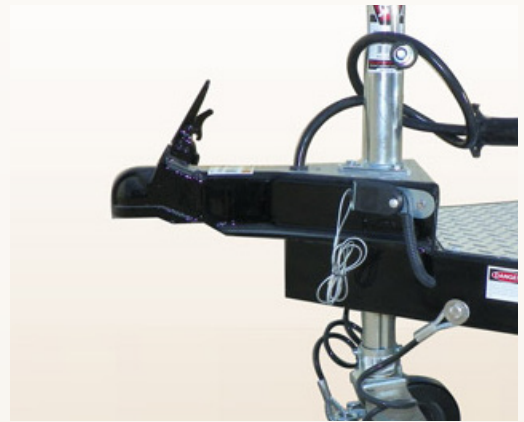

Please see individual online model descriptions for specific features, warranties, and pricing.

Click to design
your trailer with
our **FREE** tool!

Ready to Start Designing Your New Bumper Pull Trailer?



www.doubledtrailers.com

Use our Trailer Finder Tool to find models that match your needs.

Then, click "Customize" on any model to start selecting your custom features and style.

[Click to Find Your New Trailer](#)

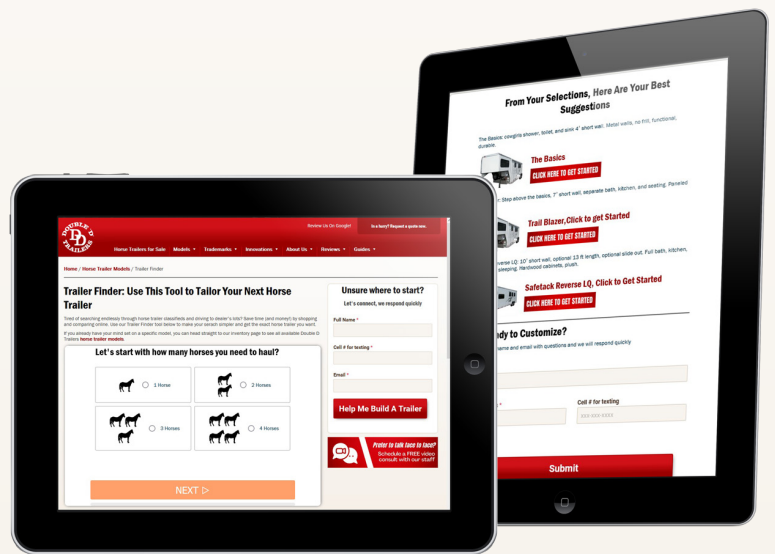

Share this brochure with a friend! We're a family-oriented business and we appreciate your referrals. Much thanks, Brad Heath :)

We're here to help!
www.doubledtrailers.com/contact-us/